



# CP Metering Drum



## Optimize Separation

The heavy-duty rotating CP Metering Drum continually levels the burden depth of material on the belt. The electric eye focuses on the transition between the horizontal feed and the incline conveyor optimizing the amount of material flowing from the feeder into the system for maximum efficiency. Increases labor efficiency because it eliminates the need for loader operator to be “married” to the infeed, enabling them to multi task between loads.

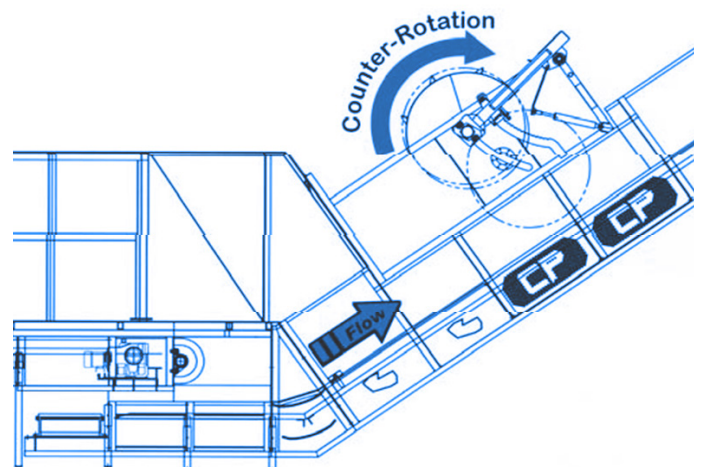

800-462-5311 | [info@cpgrp.com](mailto:info@cpgrp.com)  
6795 Calle de Linea, San Diego, CA 92154 | [www.cpgrp.com](http://www.cpgrp.com)

Made in the  
**USA**

# CPG CP Metering Drum



## Benefits

- The CP Metering Drum is an automated system that assures consistent material flow for Commercial and Single Stream applications
- Dramatically reduces dependency on loader operator, increasing labor efficiency
- Increases system capacity and throughput while preventing surges
- Allows for more efficient manual sorting
- Decreases downtime caused by over-feed surges

## Features

- The CP Metering Drum features an electric eye located on the in-feed side of the drum that senses the material burden depth from the primary feed conveyor and sends signals to the feed conveyor to resume when material is depleted
- When the material burden depth is enough to maintain constant material flow, the primary feed conveyor is automatically stopped
- In Single Stream applications, the cleats of the counter-rotating drum cut the top off material that exceeds the “burden depth” of the drum (the distance between the bottom of the drum and the top of the conveyor belt), to maintain a constant flow of material

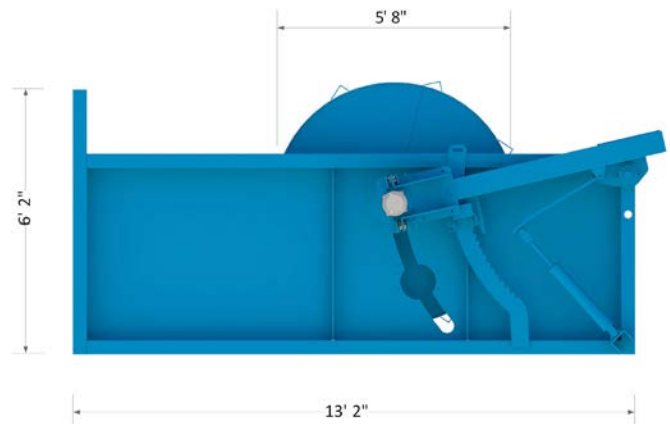

Overall Width:  
Conveyor width + 4' 2"

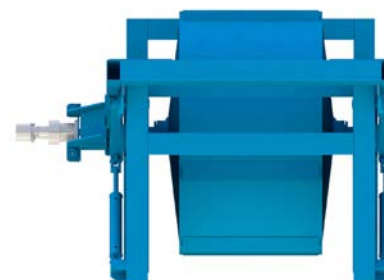

For 36", 48", 60", and 72"  
Conveyor Widths



800-462-5311 | [info@cpgrp.com](mailto:info@cpgrp.com)

6795 Calle de Linea, San Diego, CA 92154 | [www.cpgrp.com](http://www.cpgrp.com)

Made in the  
USA